

Manifold

MRU



Description

The manifold can be used for both supply and exhaust air. It is available in several types and dimensions. All types have $\text{\O} 63$ mm studs with Lindab Safe sealings for connections of either SR 63 spiral-seamed ducts or semiflexible ducts LFPE. The manifold is designed for floor installation but can be used everywhere, also in the ceiling for example. The Smart lock function allows you to fasten semiflexible ducts effortlessly to the $\text{\O} 63$ connections. Two turnable anchor plates, placed on the bottom of the manifold, can be used for fixation. Fulfills air tightness class D.

Technical data

Supply

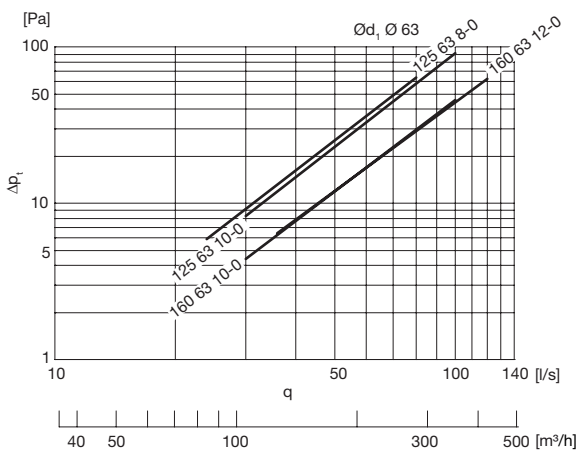

Ordering example

Product	MRU	160	63	12-0
Dimension $\text{\O}d_1$				
Dimension $\text{\O}d_3$				
Type				

Dimensions

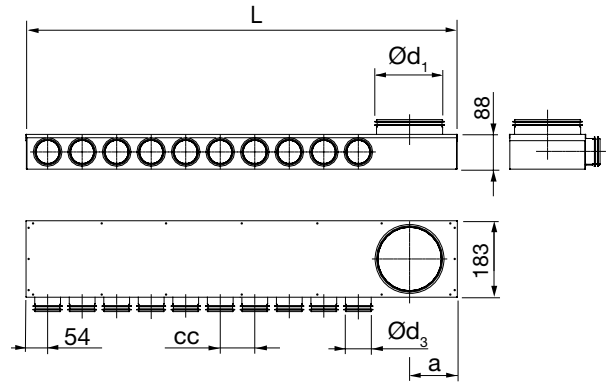

$\text{\O}d_1$ nom	$\text{\O}d_3$ nom	Type	L mm	cc mm	a mm	m kg
125	63	8-0	888	93	85	3,20
125	63	10-0	1072	93	85	3,90
160	63	10-0	1173	98	102	3,85
160	63	12-0	1293	93	102	4,50

Exhaust

